

REGI U.S., INC. / REG TECHNOLOGIES INC.

#240 – 11780 Hammersmith Way, Richmond, BC V7A 5E9
Phone: 604-278-5996 Fax: 604-278-3409 Toll Free: 800-665-4616
www.regtech.com info@regtech.com

RADMAX® TECHNOLOGY

Proposal for Automobile Industry

1. Summary

It is recommended that U.S. Automobile Companies look at licensing the RadMax® technology and locate its headquarters and research & development operations in this country. This would offer the United States the opportunity to take the automobile in an entirely new direction, based on a novel drivetrain, built-in field upgradability, a whole new type of aftermarket and wider distribution channels. The U.S. may never again have such an opportunity, one which promises extremely significant industrial benefits.

2. Proposal

2.1 This proposal is based on the following beliefs about the future:

-there will be continual and significant **increases in the cost of fuel**.

-more **fuel efficient vehicles** will be in high demand

-**changes in society** and the workplace will occur due to the increased costs of transportation

-there will be **massive growth in the home workplace** – a great percentage of U.S. workers are information workers and an increasing number of them will begin to work from home on a part-time or full-time basis;

-there are major **environmental, energy and economic (E3) benefits** to the home workplace including less pollution, lower fuel consumption and lower operating costs for business;

-if a worker commutes only one or two days per week they are free to locate much farther from their office and **many home workers will choose to live much farther away** from downtown areas, in both far-suburban and rural non-farm situations where costs are lower and family quality of life is superior; and

-suburban, far-suburban and rural residents who spend more time at home will be in a position to **create more of their own energy** and **grow more of their own food** at their homes.

2.2 Recent developments in rotary engines and power-control electronics provide the opportunity to create a vehicle which would use a rotary engine for a series or parallel hybrid drive. Shown in FIGURE 1 is the widely used parallel hybrid drive.

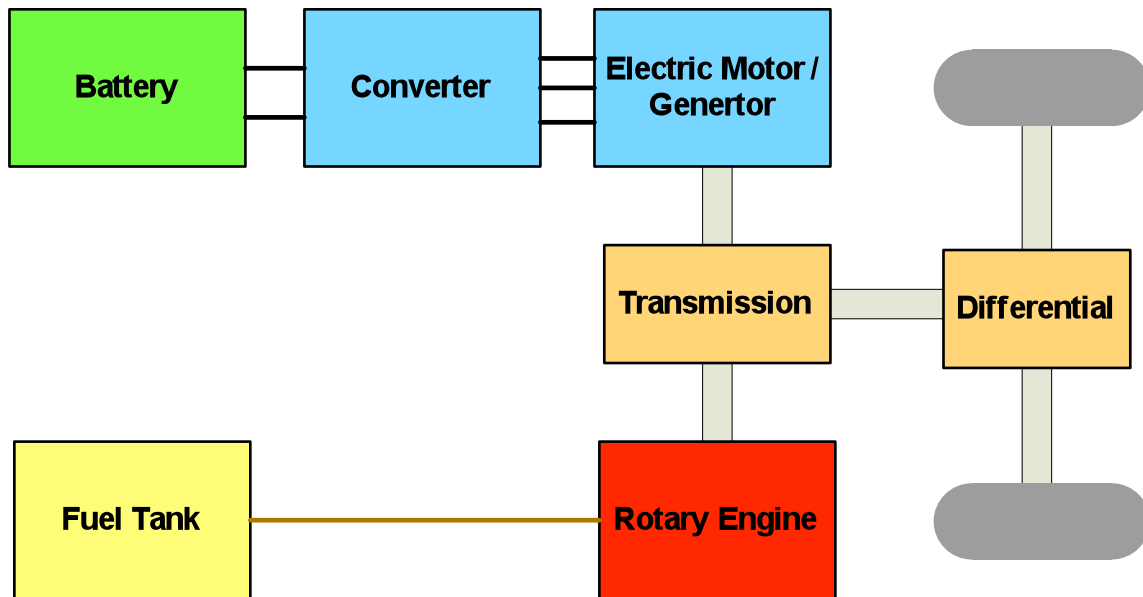

FIGURE 1 - ROTARY-ELECTRIC DRIVE LAYOUT

2.3 Such a car would have several important advantages:

- the rotary engine can be designed to **burn almost anything** - gasoline, diesel fuel, ethanol, jet fuel, paraffin, kerosene, stove oil, compressed natural gas, etc

- rotary engines provide **high efficiency** and **complete burning of fuel** when run at an optimal, constant high speed;

- intelligent power controllers can be used to **optimize the efficiency** of the hybrid drive train for the real time operating condition of the vehicle

- during braking, the electric motor operates in reverse mode as a dynamic brake, turning kinetic energy back into electrical energy **recharging the batteries** saving fuel during urban driving.

- vehicle power controls turn off the engine at stops and low speed. The vehicle then operates in the electric mode **saving fuel and reducing emissions**.

- suburban and rural residents could buy fermenters and stills which would permit them to **produce some of their own fuel** from crop grains and many other types of other organic materials.

2.4 The **RadMax® engine** is a rotary engine so it could be used in advanced drivetrain vehicles. The RadMax engine was developed in Canada and the U.S. could obtain an exclusive license to build it for auto and light truck use for a protected period of time. The key advantages of RadMax® technology are its simple design (only two unique rotors), its high approximate one-to-one horsepower-to-weight ratio, and its capability to be designed to burn multiple types of fuel including gasoline, diesel, ethanol, hydrogen and natural gas. The 6" and 10" diameter prototype diesel engines are expected to produce about 40 brake hp at 3,000 rpm (weighs approx. 40 lbs) and 100 brake hp at 3000 rpm (weighs approx. 100 lbs) respectively. Up to 24 combustion events per engine revolution produce a smooth, quiet engine. They believe their current engine design to be scalable between 15 and 5,000 horsepower. See FIGURE 2 below.

FIGURE 2 - RADMAX® ENGINE

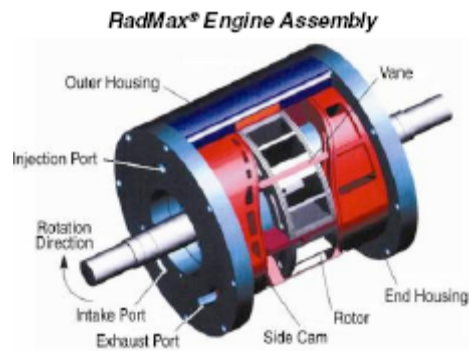

The RadMax® offers a lighter, smaller engine which permits reduction of chassis weight and overall vehicle weight. Given the smaller volume needed for the powerplant, the number of layout and styling options open to vehicle designers increases dramatically. RadMax® is also experimenting with an integrated rotary engine - generator unit, by building the generator windings and magnets right into their engine which (if successful) would further reduce both weight and the number of major power-train components. See FIGURE 3 below.

FIGURE 3 - INTEGRATED ROTARY ENGINE AND GENERATOR

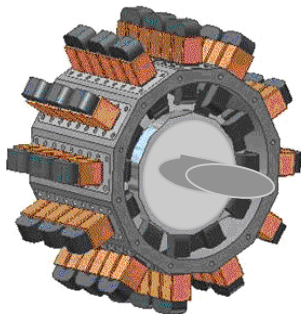

>>> *The above claims originate with RegTech, who developed the RadMax® engine, and believes that there is now sufficient technology available to engineer, develop and produce the type of vehicles described above. RadMax® claims to have achieved significant progress and believes that, once their claims are validated, they will be invited to become a serious contender for the powerplant of the proposed new U.S. built vehicles.*

2.5 The vision is that the car would be built in a modular fashion so that major engine and drivetrain components **could be progressively upgraded** to extend the life of the vehicle.

2.6 The vehicle should also have an **open electronics architecture**, with published interface specifications among all major components. This would permit independent software and chip makers to serve the aftermarket for electronic additions and upgrades to the vehicle as long as the changes are certified by the vehicle manufacturer. There are many critical safety issues with the software controlling all aspects of the vehicle operation. The wide spread use of uncertified components could lead to accidents and cause additional litigation.

2.7 The most logical **progression of model rollouts** would be as follows:

Platform A - Full Size

A-1 Four-door sedan

A-2 Four-door mini-van (same platform as sedan, but with a taller and longer body)

A-3 Two-door pickup-utility (similar to the "Utes" always seen in Australia and the earlier Chevrolet El-Camino or Ford Ranchero, basically the hood, dash panel and front seat of a sedan forward of the B-Pillar and a pickup-style box aft of the B-Pillar)

A-4 Luxury, high-performance sedan with longer wheelbase and twin engines.

Platform B - Compact

B-1 Four-door sedan

B-2 Four-door crossover Sport Utility Vehicle

B-3 Open Jeep Utility style

>>> *Note that, by definition, all of these vehicles have built-in traction control, anti-lock brakes and regenerative braking, but each could be priced well below directly competitive vehicles due to its simpler design, lower manufacturing cost and much lower part count.*

2.8 These new-generation vehicles should be distributed via four channels:

-small-entrepreneur **agencies** which work closely with customers to help them order what is for them the optimal base vehicle and options, and who also provide linkages to aftermarket providers, but who do not provide on-lot vehicle

inventories nor maintenance service - until the late 1950's a significant percentage of the cars in North America were sold by such agencies and they offer the advantage of being able to give unhurried and sensitive, personal service to the large number of consumers who dislike traditional auto salesmen and thus detest the current car-buying experience;

-full-service traditional **dealerships** offering sales, new-vehicle inventory and maintenance service;

-**value-added-resellers** who make significant physical and/or electronic additions to the new vehicle and offer it as a premium, semi-custom package; and

-a highly specialized **export organization** optimized to Third-World conditions which provisions the vehicles (with additional spare parts, alternative body components and support equipment) for long-term self-sufficiency in operating environments where technical support is not available - this type of organization would also provide internationalization of vehicle software and documentation.

2.9 For suburban and rural residents here in North America, and for the export markets, the car would be optionally available with a microprocessor-controlled, stand-alone **still device used to distill a wide variety of plant matter** into a fuel suitable for the engine.

2.10 The RadMax®-electric car would have far fewer parts than a conventional full-size car so it would be simpler and cheaper to build and would thus have both a **lower selling price** and a **lower life-cycle cost** because turbine and RadMax® type engines will require far less maintenance than conventional engines, just as jet aircraft engines require less than half the maintenance (per flight-hour) of piston engines.

2.11 The new vehicle product line would in fact be more **energy-efficient** and **environmentally friendly** than most current compact and intermediate cars.

2.12 Since many of the batteries now used in electric cars have significant common component, the marketplace will evolve to several **standardized electric battery units** - across all makes and models of hybrid and electric cars. This process will lead to lower battery costs and wider availability. There is the possibility of developing rapid recharge stations that to extend the electric only use of the vehicle

3. Rationale

3.1 This approach would have the following advantages:

-instantly **make U.S. the dominate tier-one auto nation** with its own domestically based (and internationally competitive) industry, this would afford us the ability to significantly increase foreign exchange earnings from incremental offshore exports of a unique vehicle product line;

-increase auto-related **research and development** work in U.S.;

-provide an existing **worldwide distribution network** plus the U.S.-owned foreign operating companies which could produce or become outlets for the new-generation rotary-electric product line; and

-**guarantee parts and assembly manufacturing jobs** here for the long term.

3.2 No other manufacturer in any other nation offers a vehicle of the type proposed and it would therefore have some unique market advantages, including:

-ability to **replace major components** such as engine, generator/alternator, in-wheel drive motors some body components as upgraded ones become available;

-far higher attractiveness in **Third-World markets** due to its wide range of fuels, simplicity and field-upgradability - and the fact that we will export it with a complete self-support kit - *we might even penetrate the Chinese market*; and

3.4 The industrial spin-offs from such a venture are almost beyond calculation and will include:

-stimulation of a world-leading rotary **engine industry** based here in U.S. with many applications to other areas such as static power generation, pumping stations, snowmobiles and ATV's, pleasure boat propulsion etc.;

-many opportunities for increased specialized electronic (software and hardware) and physical **component production** in U.S.;

-creation of new **agency** and **value-added-reseller** distribution channels; and

-ability to **vastly increase the number of vehicles exported** offshore, almost all of which will be net gains in auto production - this also includes the ability to locate most of this **production growth in U.S.**

4. Execution Plan

Create a **Pilot Team** with representatives from automobile companies to create an advanced technology industry and the automotive industry (engineering and marketing disciplines) to fully assess the above proposal and to design both a Task Force and workplan to accomplish this objective. A formal business case (including risk management plan) would also be produced at this stage.

6. Summary

The factors discussed above would give the U.S. companies a competitive edge over ALL other worldwide auto manufacturers, assist the Americans to reduce their dependency on foreign oil and help to reduce the global warming concerns through greater fuel-efficiency as well as more efficient combustion. In turn, this would further benefit the U.S. economy in by creating more jobs due to increased demand for more efficient automobiles.